



INTERPUMPGROUP

I GB F	ISTRUZIONI D'USO INSTRUCTIONS FOR USE MODE D'EMPLOI	D E P	BEDIENUNGSANLEITUNG INSTRUCCIONES DE USO INSTRUÇÕES DE USO
-----------------------	--	----------------------	---

Questo manuale deve essere letto e compreso in accordo al libretto generico "Istruzioni d'uso e manutenzione".
 This manual must be read and followed in accordance with the generic "Instructions for Use and Maintenance" booklet.
 Ce manuel doit être lu et compris en accord avec la notice générale "Mode d'emploi et d'entretien".
 Dieses Handbuch ist in Verbindung mit dem allgemeinen Handbuch "Gebrauchs- und Wartungsanleitung" zu lesen und zu verstehen.
 Este manual debe leerse y comprenderse de acuerdo con el manual general "Instrucciones de uso y mantenimiento"
 Este manual deve ser lido e interpretado de acordo com o livro genérico "Instruções de uso e manutenção"

69

**S
E
R
I
E
S**



Type Type Type Tipo	Flow rate Débit Förderstrom Caudal Portata		Pressure Pressione Druck Presion Pressione			rpm t/m upm r/m g/m	Power Puissance Leistung Potencia Potenza		Weight Poids Gewicht Peso Massa		
	L/min	gpm	bar	MPa	psi		Hp	KW	Kg	Ibs	
W4 T41	42	11.10	50	5	725	600	5.5	4.04	16.5	36.30	1.3
W827 T8271	68	18.00	82	8.2	1200	1000	14.5	10.66	25.8	56.80	1.3
WS104 TS1041	30	7.92	100	10	1450	1450	7.5	5.51	20.5	45.10	1.3
WS153 TS1531	30	7.92	150	15	2175	1450	10.0	7.35	21	46.20	1.3

**KIT RICAMBI – SPARE KITS****W827 – T8271**

KIT Nr.	KIT 32	KIT 37	KIT 40	KIT 41	KIT 43	KIT 188	KIT 189	KIT 190
Posizioni include Positions included	38	11	45 - 46	48	3 - 4 5 - 6 7 (10)	49	45 - 46 47 - 48 49 - 50 56	47 - 50 56
Nr. Pcs.	2	3	3	3	6	3	1	3

POS	COD.	DESCRIZIONE – DESCRIPTION - KIT	NR
1	99.3810.00	Vite M10x95 UNI 5931	8
2	96.7104.00	Rosetta Ø 10.5x16x1	8
3	90.4059.00	OR Ø 32.93x3.53 (4131)	43 6
4	36.2011.66	Sede valvola	43 6
5	36.2010.76	Valvola sferica	43 6
6	94.7450.00	Molla Ø 16x27.5	43 6
7	36.2009.51	Guida valvola	43 6
8	90.4065.00	OR Ø 37.69x3.53 (4150)	6
9	98.2420.00	Tappo M42x1.5x53	6
10	36.7065.01	Gruppo valvola aspiraz./mandata	43 6
11	90.1656.00	Anello rad. Ø 32x42x7	37 3
12	69.0100.22	Carter pompa	1
13	98.2106.00	Tappo carico olio G 3/8"	1
14	69.2119.84	Guarnizione coperchio posteriore	1
15	69.2196.66	Vite fissaggio pistone	3
16	90.3859.00	OR Ø 25.07x2.62 (3100)	3
19	69.0400.09	Pistone Ø 36x60	3
20	69.0205.35	Albero eccentrico C.24	1
21	91.4969.00	Linguetta 10x8x40 UNI 6604	1
22	90.0695.00	Anello seeger Ø 35 UNI 7435	1
23	69.1600.22	Coperchio posteriore carter	1
24	69.0304.01	Biella – Completa	3

POS	COD.	DESCRIZIONE – DESCRIPTION - KIT	NR
26	99.3099.00	Vite M8x35 UNI 5931	6
27	90.3833.00	OR Ø 13.95x2.62 (3056)	1
28	97.5968.00	Spia livello olio G 3/4"	1
29	98.2100.50	Tappo G 3/8"x13 TE22 – Zinc.	1
30	99.1867.00	Vite M6x18 UNI 5931	9
31	97.7398.00	Spinotto Ø 14x31.5	3
32	69.0503.54	Guida pistone	3
34	96.7565.00	Rosetta Ø 22.3x42x0.5	3
35	99.3636.00	Vite M10x16 UNI 5739	8
36	68.1500.74	Coperchio laterale carter	2
37	69.2115.51	Distanziale	1
38	90.1672.00	Anello rad. Ø 35x52x8	32 1
39	90.4131.00	OR Ø 73.03x3.53 (176)	2
40	91.8482.00	Cuscinetto a rulli NJ 307 ECP	2
41	47.2000.74	Piedino pompa	2
42	90.9162.00	Boccola Ø 32x36x40	3
43	96.7106.00	Rosetta Ø 10.5 DIN 7980	4
44	99.3644.00	Vite M10x18 UNI 5931	4
45	90.3885.00	OR Ø 45.69x2.62 (3181)	40-189 3
46	69.0802.70	Anello di fondo Ø 36	40-189 3
47	90.2820.00	Anello ten. alt. Ø 36x48x6/3.5 HP	189-190 3

POS	COD.	DESCRIZIONE – DESCRIPTION - KIT	NR
48	69.1002.93	Anello di testa Ø 36	41-189 3
49	69.2170.70	Anello intermedio Ø 36	188-189 3
50	90.2818.00	Anello RESTOP Ø 36x48x6/3	189-190 3
51	98.2325.00	Tappo G 1"x17	1
52	96.7870.00	Rosetta Ø 33.5x38x1.5	1
53	96.7700.00	Rosetta Ø 26.5x32x1.5	1
54	69.1218.41	Testata pompa	1
55	69.2116.51	Distanziale	1
56	90.2823.00	Anello ten. alt. Ø 36x48x7.5 LP	189-190 3
57	98.2265.00	Tappo G 3/4"x16	1

1 - CAMBIO OLIO

- 1.1 – Il cambio dell'olio va eseguito con pompa a temperatura di lavoro.
- 1.2 – Posizionare un recipiente sotto il tappo di scarico olio (3).
- 1.3 – Rimuovere il tappo con asta (1) e successivamente il tappo di scarico (3).
- 1.4 – Attendere fino a quando tutto l'olio è uscito, quindi riavvitare il tappo di scarico (3) con la coppia torcente indicata su disegno esploso.
- 1.5 – Riempire con olio nuovo fino al raggiungimento della mezzeria del tappo spia livello olio (2) e riavvitare il tappo con asta (1).

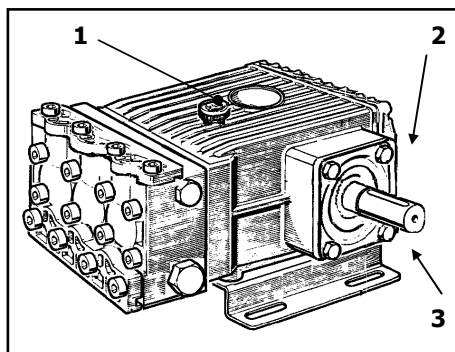

Per il tipo di olio da utilizzare fare riferimento a quanto indicato sul libretto generico.



ATTENZIONE: L'olio esausto deve essere raccolto in recipienti e smaltito negli appositi centri in accordo alla normativa vigente. Non deve essere assolutamente disperso nell'ambiente.

1 – OIL CHANGING

- 1.1 – Oil changing must be done with the pump at operating temperature.
- 1.2 – Put a container under the oil drain plug (3).
- 1.3 – Remove the oil dipstick (1) and then the drain plug (3).
- 1.4 – Wait until all the oil has drained out, then screw the drain plug (3) and tighten at the torque shown in the exploded diagram.
- 1.5 – Fill with new oil until the middle of the oil level indicator (2) is reached, screw by hand the oil dipstick (1).

Refer to the generic booklet for the type of oil to use.



WARNING: The exhaust oil must be collected in receptacles and disposed of at authorised centres as specified by law. It must not be thrown away in the environment.

1 - CHANGEMENT DE L'HUILE

- 1.1 – Le changement de l'huile doit être exécuté avec la pompe à température d'exercice.
- 1.2 – Placer un récipient sous le bouchon de vidange de l'huile (3).
- 1.3 – Enlever le bouchon-jauge (1), puis enlever le bouchon de vidange (3).
- 1.4 – Attendre que toute l'huile soit sortie, puis revisser le bouchon de vidange (3) avec le couple de torsion qui est indiqué sur le dessin éclaté.
- 1.5 – Remplir avec de l'huile neuve jusqu'à la ligne médiane du bouchon indicateur du niveau d'huile (2), et revisser le bouchon-jauge (1).

Pour le type d'huile à utiliser, se référer à ce qui est indiqué sur la notice générale.



ATTENTION : L'huile usée doit être recueillie dans des récipients et éliminée dans les centres prévus à cet effet, conformément à la réglementation en vigueur. Il ne faut absolument pas la jeter dans l'environnement.