

**HOCHDRUCK-PLUNGERPUMPEN
HIGH-PRESSURE PLUNGER PUMPS**

**BAUREIHE
SERIES P71**

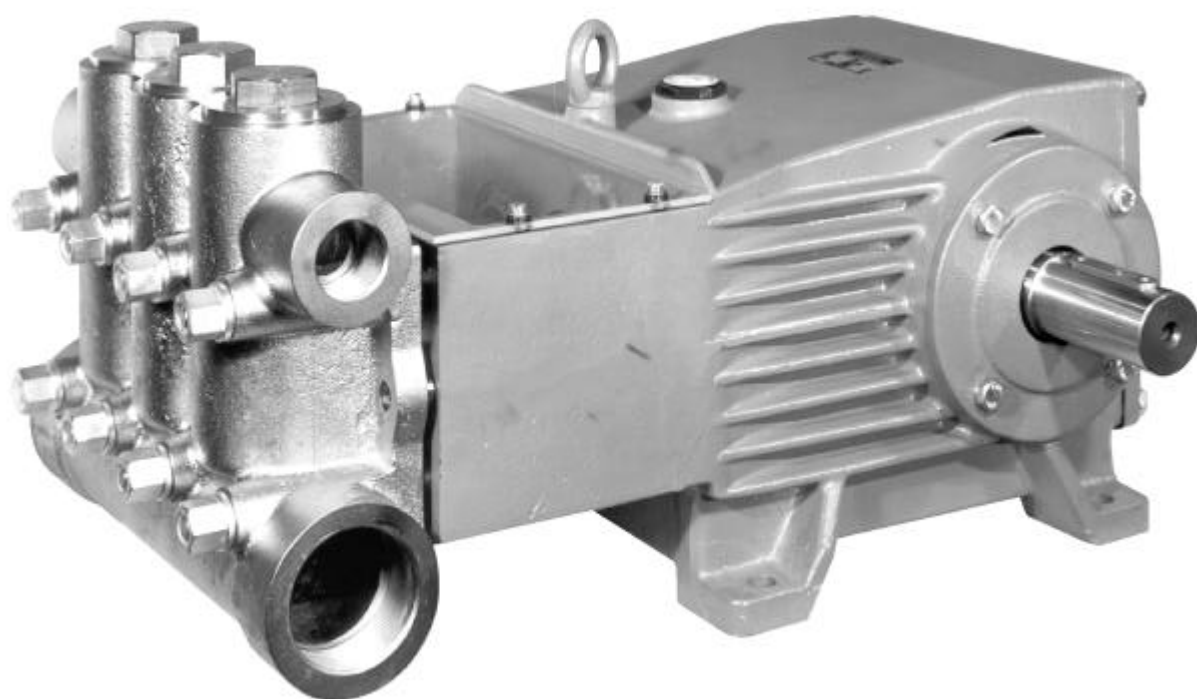

Type	Best.-Nr.	Leistungs- aufnahme	Überdruck max.	Drehzahl max.	Förder- menge max.	Wasser temp. max.	Plunger -Ø	Hub	Gewicht ca.	NPSHR
	Code No.	Power Consump.	Pressure max.	RPM max.	Output max.	Water- Temp. max.	Plunger dia.	Stroke	Weight approx.	NPSH Required
		kW	bar	min ⁻¹	l/min	°C	mm	mm	kg	mWs
P71/40-700	00.5204	51.7	700	750	37.5	60	22	52	170	9.0
P71/50-500R	00.4432	47.2	500	750	48.0	60	24	52	170	9.7
P71/70-400	00.4871	53.3	400	750	67.7	60	28	52	170	-
P71/90-300	00.4316	52.3	300	750	88.5	60	32	52	170	9.5
P71/110-250	00.4317	52.7	250	700	107.0	60	36	52	170	9.7
P71/145-180	00.4318	51.5	180	700	145.3	60	42	52	170	8.5
P71/145-180G	00.4354	51.5	180	700	145.3	60	42	52	170	8.5
P71/200-130	00.4319	52.7	130	700	205.8	60	50	52	170	10.5
P71/200-130G	00.4501	52.7	130	700	205.8	60	50	52	170	10.5
P71/250-100	00.4310	49.0	100	700	249.1	60	55	52	170	11.5
P71/250-100G	00.4355	49.0	100	700	249.1	60	55	52	170	11.5

Einsatzgebiete

SPECK TRIPLEX Plungerpumpen sind geeignet zur Förderung von sauberem Wasser oder anderen nicht aggressiven oder abrasiven Medien mit ähnlichem spezifischen Gewicht wie Wasser.

Vor dem Verpumpen anderer Fördermedien muß die Eignung und Beständigkeit der Pumpen in Standard oder Sonderausführung unter Berücksichtigung der Leistungs- und Temperaturwerte geprüft werden.

Konstruktionsmerkmale

Die Pumpen der Baureihe P71 zeichnen sich aus durch:

- Antriebsgehäuse aus starkem Sphäroguß für hohe Stabilität und Schwingungsdämpfung.
- Kurbelwelle mit Kegelrollenlager und Gleitlagerpleuel im Ölbad laufend.
- Plunger aus Vollkeramik, P71/40, /50, /70 hartmetallbeschichteter Edelstahl.
- Doppelte Plungerabdichtung.
- Alle Dichtungen in Hülsen gehalten, dadurch exakte Zentrierung und erleichterter Austausch.
- Saug- und Druckventile baugleich, über Stopfen leicht zugänglich.

Verwendete Werkstoffe

- Ventilgehäuse: Bronze, bzw. G-Versionen Sphäroguß vernickelt P71/70, /90 und /110 mit Ventilgehäuse aus Edelstahl 1.4305. P71/40, /50 mit Ventilgehäuse aus Edelstahl 1.4313.
- Plunger: Vollkeramik bzw. P71/40, /50, /70 Edelstahl mit Hartmetallbeschichtung.
- Ventile: Duplexstahl.
- Manschetten: NBR mit Gewebeeinlage (P71/40, /50 Aramidpackung).
- Kurbelwelle: Gesenkgeschmiedet und einsatzgehärtet.

Betriebsbedingungen

Trotz des pulsationsarmen Laufes der Pumpen muß von Fall zu Fall geprüft werden, ob ein Druckspeicher vorzusehen ist. Dies hängt im wesentlichen ab von der Konstruktion des Gerätes und von der Gesamtheit der Betriebsbedingungen. Die Funktion eines Druckspeichers kann auch von elastischen Druckleitungen übernommen werden. Besondere Sorgfalt ist bei Betrieb mit warmem Wasser erforderlich. Kavitation muß auf jeden Fall vermieden werden.

Sicherheitsvorschriften und Garantie

Die Garantie beträgt 6 Monate nach VDMA.

Es ist ein Sicherheitsventil gemäß den "Richtlinien für Flüssigkeitsstrahler" vorzusehen, das so eingestellt ist, daß der Betriebsdruck um nicht mehr als 10% überschritten werden kann. Bei Nichteinhaltung dieser Vorschrift sowie bei Überschreiten der Temperatur- und Drehzahlgrenze erlischt jegliche Garantie.

P71/145-180(G)

P71/200-130(G)

P71/250-100(G)

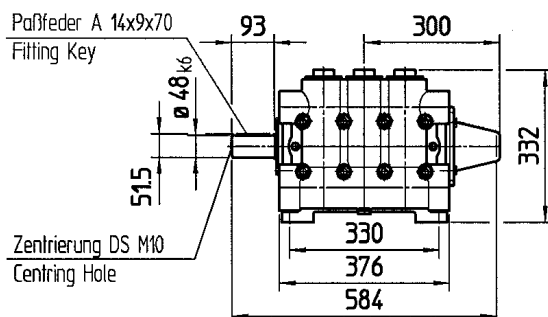

Fields of Application

SPECK TRIPLEX Plunger Pumps are suitable for pumping clean water and other non-aggressive or abrasive media with a specific weight similar to water.

Prior to pumping any other media, a check must be made to find out whether these pumps, taking pump performance and temperature values into consideration, are at all suitable for pumping the required medium.

Construction Characteristics

Particular features of the P71 series are:

- Crankcase of solid sphero-cast-iron ensuring stability and vibration dampening.
- Crankshaft and taper roller bearings together with plain bearing con rod all run in oil.
- Solid ceramic plunger - P71/40, /50, /70 hard metal-coated stainless steel.
- Double plunger sealing.
- All gaskets in seal sleeves ensuring precise centring and easy replacement.
- Identical suction and discharge valves, easily accessible.

Materials Used

- Valve Casing: Bronze, G-versions of nickel-plated sphero-cast-iron, P71/70, /90 and /110 valve casings of stainless steel AISI 303. P71/40 and /50 valve casing of stainless steel UNS J 91540.
- Plunger: Solid ceramic - P71/40, /50, /70 hard metal-coated stainless steel.
- Valves: Duplex-Steel.
- Sleeves: Nitrile with fabric reinforcing (P71/40, /50 Aramid-Packing).
- Crankshaft: Drop-forged and case-hardened.

Installation

Even though SPECK-TRIPLEX P71 pumps run almost pulsation-free, there are cases where a pressure accumulator is necessary. This will depend mainly on the construction of the unit and the conditions under which it is operated. The same effect can also be achieved by using flexible pressure lines. In any case, use of a pulsation damper adds considerably to the life of the seals and bearings.

Particular care has to be taken when pumping warm water, making absolutely sure that cavitation can not occur.

Safety and Warranty Rules

There is a 6 month warranty in accordance with VDMA guidelines.

Pump operation without safety valve as well as any excess in temperature or speed limits automatically voids the warranty. The safety valve must be regulated in accordance with the guidelines for liquid spraying units so that the admissible operating pressure can not be exceeded by more than 10%.

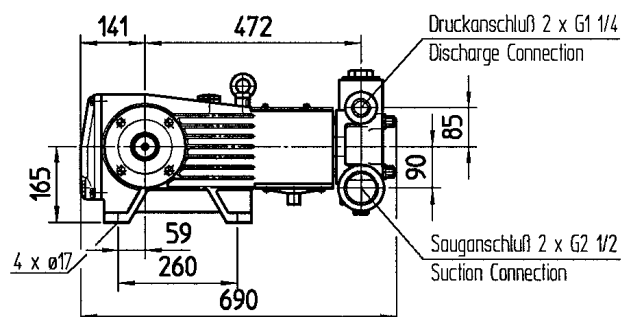

P71/70-400
P71/90-300
P71/110-250

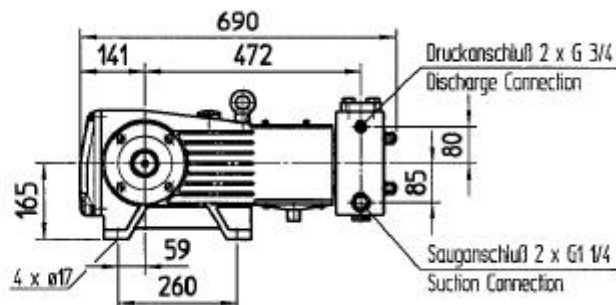
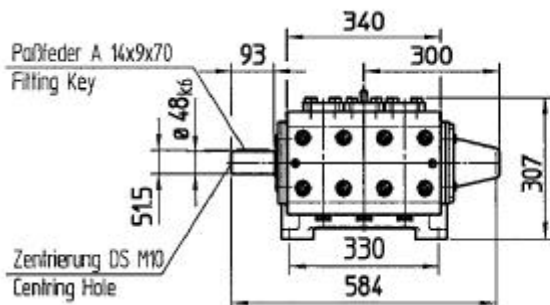

P71/40-700
P71/50-500R

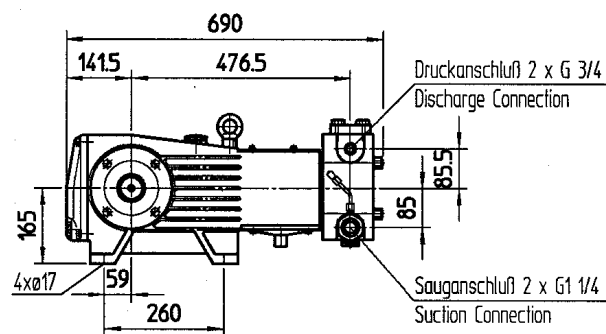
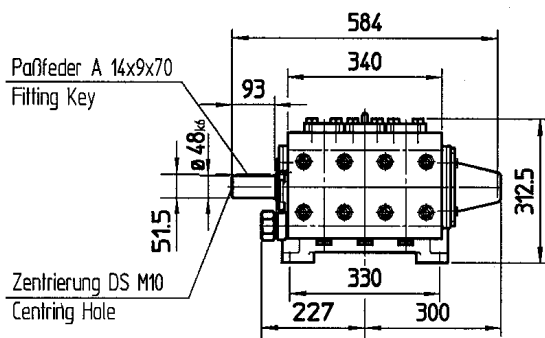

Leistungstabellen – Performance Table

Motorleistung in kW / Motor Performance KW P71/40-700							Überdruck / Pressure		max. 700 bar					
							Fördermenge / Output		max. 2250 l/h					
							Wassertemp. / Water Temp.		max. 60 °C					
							Gewicht / Weight		ca./approx. 170 kg					
Fördermenge Output		Pumpen- drehzahl RPM	Pumpen- keilscheibe Pump V-Belt Pulley		Motor- keilscheibe Motor Pulley bei/at 1450/min		2 x XPB		Druck in bar Pressure in bar					
I/min	I/h	1/min	Wirk-ø Eff.Dia. mm	Außen-ø Ext.Dia. mm	Wirk-ø Eff.Dia. mm	Außen-ø Ext.Dia. mm	400	500	550	600	650	700		
15.0	900	300	630	639	130	139	11.8	14.8	16.2	17.7	-	-	3 x XPB	
20.0	1200	400	630	639	174	183	15.7	19.7	21.7	23.6	25.6	-		
25.0	1500	500	400	409	137	146	19.7	24.6	27.1	29.5	32.0	34.4	5 x XPB	
30.0	1800	600	400	409	166	175	23.6	29.5	32.5	35.4	38.4	41.3		
37.5	2250	750	315	324	163	172	29.5	36.9	40.6	44.3	48.0	51.7		
Anzahl der Keilriemen Profil XPB* Number of XPB V-Belts*							4 x XPB			5 x XPB		6 x XPB		

Motorleistung in kW / Motor Performance KW P71/50-500R							Überdruck / Pressure		max. 500 bar					
							Fördermenge / Output		max. 2880 l/h					
							Wassertemp. / Water Temp.		max. 60 °C					
							Gewicht / Weight		ca./approx. 170 kg					
Fördermenge Output		Pumpen- drehzahl RPM	Pumpen- keilscheibe Pump V-Belt Pulley		Motor- keilscheibe Motor Pulley bei/at 1450/min		2 x XPB		Druck in bar Pressure in bar					
I/min	I/h	1/min	Wirk-ø Eff.Dia. mm	Außen-ø Ext.Dia. mm	Wirk-ø Eff.Dia. mm	Außen-ø Ext.Dia. mm	200	300	350	400	450	500		
19.2	1152	300	630	639	130	139	7.6	11.3	13.2	15.1	-	-		
25.6	1536	400	630	639	174	183	10.1	15.1	17.6	20.2	22.7	-		
32.0	1920	500	400	409	137	146	12.6	18.9	22.0	25.2	28.3	-		
38.4	2304	600	400	409	166	175	15.1	22.7	26.5	30.2	34.0	37.8	5 x	
48.0	2880	750	315	324	163	172	18.9	28.3	33.1	37.8	42.5	47.2		
Anzahl der Keilriemen Profil XPB* Number of XPB V-Belts*							3 x XPB		4 x XPB		5 x XPB		6 x XPB	

Motorleistung in kW / Motor Performance KW P71/70-400							Überdruck / Pressure		max. 400 bar		Fördermenge / Output		max. 4063 l/h	
							Wassertemp. / Water Temp.		max. 60 °C		Gewicht / Weight		ca./approx. 170 kg	
Fördermenge		Pumpen- drehzahl	Pumpen- keilscheibe		Motor- keilscheibe		2 x XPB		3 x XPB					
Output		RPM	Pump V-Belt Pulley		Motor Pulley bei/at 1450/min		Druck in bar Pressure in bar							
l/min	l/h	1/min	Wirk- ø Eff.Dia.	Außen- ø Ext.Dia.	Wirk- ø Eff.Dia.	Außen- ø Ext.Dia.	150	200	250	300	350	400		
27.1	1625	300	630	639	130	139	8.0	10.7	13.3	16.0	-	-		
36.1	2167	400	630	639	174	183	10.7	14.2	17.8	21.3	-	-		
45.1	2709	500	400	409	137	146	13.3	17.8	22.2	26.7	31.1	-	5 x	XPB
54.2	3251	600	400	409	166	175	16.0	21.3	26.7	32.0	37.3	42.7		
67.7	4063	750	315	324	163	172	20.0	26.7	33.3	40.0	46.7	53.3		
Anzahl der Keilriemen Profil XPB* Number of XPB V-Belts*							3 x XPB		4 x XPB	5 x XPB	6 x XPB			

Motorleistung in kW / Motor Performance KW P71/90-300							Überdruck / Pressure		max. 300 bar		Fördermenge / Output		max. 5310 l/h	
							Wassertemp. / Water Temp.		max. 60 °C		Gewicht / Weight		ca./approx. 170 kg	
Fördermenge		Pumpen- drehzahl	Pumpen- keilscheibe		Motor- keilscheibe		2 x XPB							
Output		RPM	Pump V-Belt Pulley		Motor Pulley bei/at 1450/min		Druck in bar Pressure in bar							
l/min	l/h	1/min	Wirk- ø Eff.Dia.	Außen- ø Ext.Dia.	Wirk- ø Eff.Dia.	Außen- ø Ext.Dia.	100	150	200	250	275	300		
35.4	2123	300	630	639	130	139	7.0	10.4	13.9	-	-	-		
47.2	2830	400	630	639	174	183	9.3	13.9	18.6	23.2	-	-		
59.0	3538	500	400	409	137	146	11.6	17.4	23.2	29.0	31.9	-	5 x	XPB
70.8	4246	600	400	409	166	175	13.9	20.9	27.9	34.8	38.3	41.8		
88.5	5310	750	315	324	163	172	17.4	26.1	34.8	43.5	47.9	52.3		
Anzahl der Keilriemen Profil XPB* Number of XPB V-Belts*							3 x XPB	4 x XPB		5 x XPB	6 x XPB			

Motorleistung in kW / Motor Performance KW P71/110-250							Überdruck / Pressure		max. 250 bar		Fördermenge / Output		max. 6420 l/h	
							Wassertemp. / Water Temp.		max. 60 °C		Gewicht / Weight		ca./approx. 170 kg	
Fördermenge		Pumpen- drehzahl	Pumpen- keilscheibe		Motor- keilscheibe		2 x XPB							
Output		RPM	Pump V-Belt Pulley		Motor Pulley bei/at 1450/min		Druck in bar Pressure in bar							
l/min	l/h	1/min	Wirk- ø Eff.Dia.	Außen- ø Ext.Dia.	Wirk- ø Eff.Dia.	Außen- ø Ext.Dia.	100	150	175	200	225	250		
45.9	2752	300	630	639	130	139	9.0	13.5	15.8	-	-	-		
61.2	3670	400	630	639	174	183	12.0	18.1	21.1	24.1	-	-		
76.5	4587	500	400	409	137	146	15.1	22.6	26.3	30.1	33.9	-	5 x	XPB
91.7	5505	600	400	409	166	175	18.1	27.1	31.6	36.1	40.6	45.2		
107.0	6420	700	315	324	152	161	21.1	31.6	36.9	42.1	47.4	52.7		
Anzahl der Keilriemen Profil XPB* Number of XPB V-Belts*							3 x XPB	4 x XPB		5 x XPB	6 x XPB			

Motorleistung in kW / Motor Performance KW P71/145-180(G)							Überdruck / Pressure		max. 180 bar		Fördermenge / Output		max. 8718 l/h		Wassertemp. / Water Temp.		max. 60 °C		Gewicht / Weight		ca./approx. 170 kg	
Fördermenge		Pumpen- drehzahl	Pumpen- keilscheibe		Motor- keilscheibe		2 x XPB		Druck in bar Pressure in bar													
Output		RPM	Pump V-Belt Pulley		Motor Pulley bei/at 1450/min																	
l/min	l/h	1/min	Wirk- ø Eff.Dia.	Außen- ø Ext.Dia.	Wirk- ø Eff.Dia.	Außen- ø Ext.Dia.	80	100	120	140	160	180										
62.2	3735	300	630	639	130	139	9.8	12.3	14.7	-	-	-										
83.0	4980	400	630	639	174	183	13.1	16.3	19.6	22.9	-	-										
103.7	6225	500	400	409	137	146	16.3	20.4	24.5	28.6	32.7	-										
124.5	7469	600	400	409	166	175	19.6	24.5	29.4	34.3	39.2	44.1	5 x									
145.3	8718	700	315	324	152	161	22.9	28.6	34.3	40.0	45.8	51.5										
Anzahl der Keilriemen Profil XPB* Number of XPB V-Belts*							3 x XPB	4 x XPB		5 x XPB	6 x XPB											

Motorleistung in kW / Motor Performance KW P71/200-130(G)							Überdruck / Pressure		max. 130 bar		Fördermenge / Output		max. 12348 l/h		Wassertemp. / Water Temp.		max. 60 °C		Gewicht / Weight		ca./approx. 170 kg	
Fördermenge		Pumpen- drehzahl	Pumpen- keilscheibe		Motor- keilscheibe		2 x XPB		Druck in bar Pressure in bar													
Output		RPM	Pump V-Belt Pulley		Motor Pulley bei/at 1450/min																	
l/min	l/h	1/min	Wirk- ø Eff.Dia.	Außen- ø Ext.Dia.	Wirk- ø Eff.Dia.	Außen- ø Ext.Dia.	60	80	100	110	120	130										
88.2	5293	300	630	639	130	139	10.4	13.9	17.4	-	-	-										
117.6	7057	400	630	639	174	183	13.9	18.5	23.2	25.5	-	-										
147.0	8822	500	400	409	137	146	17.4	23.2	28.9	31.8	34.7	-	5 x									
176.4	10586	600	400	409	166	175	20.8	27.8	34.7	38.2	41.7	45.2	XPB									
205.8	12348	700	315	324	152	161	24.3	32.4	40.5	44.6	48.6	52.7										
Anzahl der Keilriemen Profil XPB* Number of XPB V-Belts*							3 x XPB	4 x XPB		5 x XPB	6 x XPB											

Motorleistung in kW / Motor Performance KW P71/250-100(G)							Überdruck / Pressure		max. 100 bar		Fördermenge / Output		max. 14946 l/h		Wassertemp. / Water Temp.		max. 60 °C		Gewicht / Weight		ca./approx. 170 kg	
Fördermenge		Pumpen- drehzahl	Pumpen- keilscheibe		Motor- keilscheibe		2 x XPB		Druck in bar Pressure in bar													
Output		RPM	Pump V-Belt Pulley		Motor Pulley bei/at 1450/min																	
l/min	l/h	1/min	Wirk- ø Eff.Dia.	Außen- ø Ext.Dia.	Wirk- ø Eff.Dia.	Außen- ø Ext.Dia.	50	60	70	80	90	100										
106.7	6404	300	630	639	130	139	10.5	12.6	14.7	-	-	-										
142.3	8539	400	630	639	174	183	14.0	16.8	19.6	22.4	-	-										
177.9	10674	500	400	409	137	146	17.5	21.0	24.5	28.0	31.5	-	5 x									
213.5	12809	600	400	409	166	175	21.0	25.2	29.4	33.6	37.8	42.0	XPB									
249.1	14946	700	315	324	152	161	24.5	29.4	34.3	39.2	44.1	49.0										
Anzahl der Keilriemen Profil XPB* Number of XPB V-Belts*							3 x XPB	4 x XPB		5 x XPB	6 x XPB											

* Die in den Tabellen gewählten PKS und MKS sowie das gewählte Keilriemenprofil dienen als Anhalt für die Antriebsauslegung.

Je nach Übersetzungsverhältnis können auch Motore mit anderen Drehzahlen und entsprechend geänderte MKS / PKS verwendet werden.

Zwischengrößen von Fördermenge / Drehzahl bzw. Druck / Menge / KW können durch lineare Umrechnung ausreichend genau bestimmt werden.

Allgemeine Formel zur Ermittlung des Kraftbedarfs:

$$\frac{P \text{ (bar)} \times Q \text{ (l/min)}}{475} = \text{kW}$$

Sonderausführungen

Alle Typen der Baureihe P71 sind unter der Zusatzbezeichnung "R" mit Ventilgehäuse und Innenteilen in Werkstoff 1.4305 lieferbar.

P71 in "RE" Version (1.4571) und Sonderdichtungen auf Anfrage.

Die Type P71/250-100 ist unter der Zusatzbezeichnung "S" in Seewasserausführung lieferbar.

* The stated pump and motor pulley sizes as well as the V-belt model stated in the table serve as a guide in setting up the drive configuration.

Depending on the transmission ratio, motors with other speeds together with properly sized motor and pump pulleys can also be used.

Intermediate values for output / speed and pressure / output / kW can be established by linear extrapolation.

A general formula for calculating power is:

$$\frac{P \text{ (bar)} \times Q \text{ (l/min)}}{475} = \text{kW}$$

Special Versions

All models in the P71-series are available with valve casings and wetted parts of stainless steel AISI 303 and are marked "R".

P71 in "RE" version (AISI 316).

Special seals upon request.

The P71/250-100 is available in seawater version with the supplement letter "S".



SPECK Pumps (UK) Ltd

11 - 12 Wycombe Industrial Mall · West End Street · High Wycombe · Bucks · HP11 2QY

Tel. (01494) 523203 · Fax (01494) 441542

E-Mail: info@speck.co.uk

www.speck.co.uk