

XLT ES

Caratteristiche Tecniche

AISI 316

Technical Characteristics

Pump Pompa	Pressure Pressione		Volume Portata				RPM giri/min		Power Potenza			
			l/min		GPM				HP		kW	
	bar	PSI	50 Hz	60 Hz	50 Hz	60 Hz	50 Hz	60 Hz	50 Hz	60 Hz	50 Hz	60 Hz
XLT2520ESI	200	2900	25	30	6.6	7.9	1450	1740	13.1	15.7	9.6	11.5
XLT3020ESI	200	2900	30	36	7.9	9.5	1450	1740	15.7	18.8	11.5	13.9
XLT4020ESI	200	2900	40	48	10.6	12.7	1450	1740	20.9	25.1	15.4	18.5
XLT5620ESI	200	2900	56	67	14.7	17.6	1450	1740	29.3	35.2	21.5	25.9

Dimensioni d'ingombro

Overall dimensions

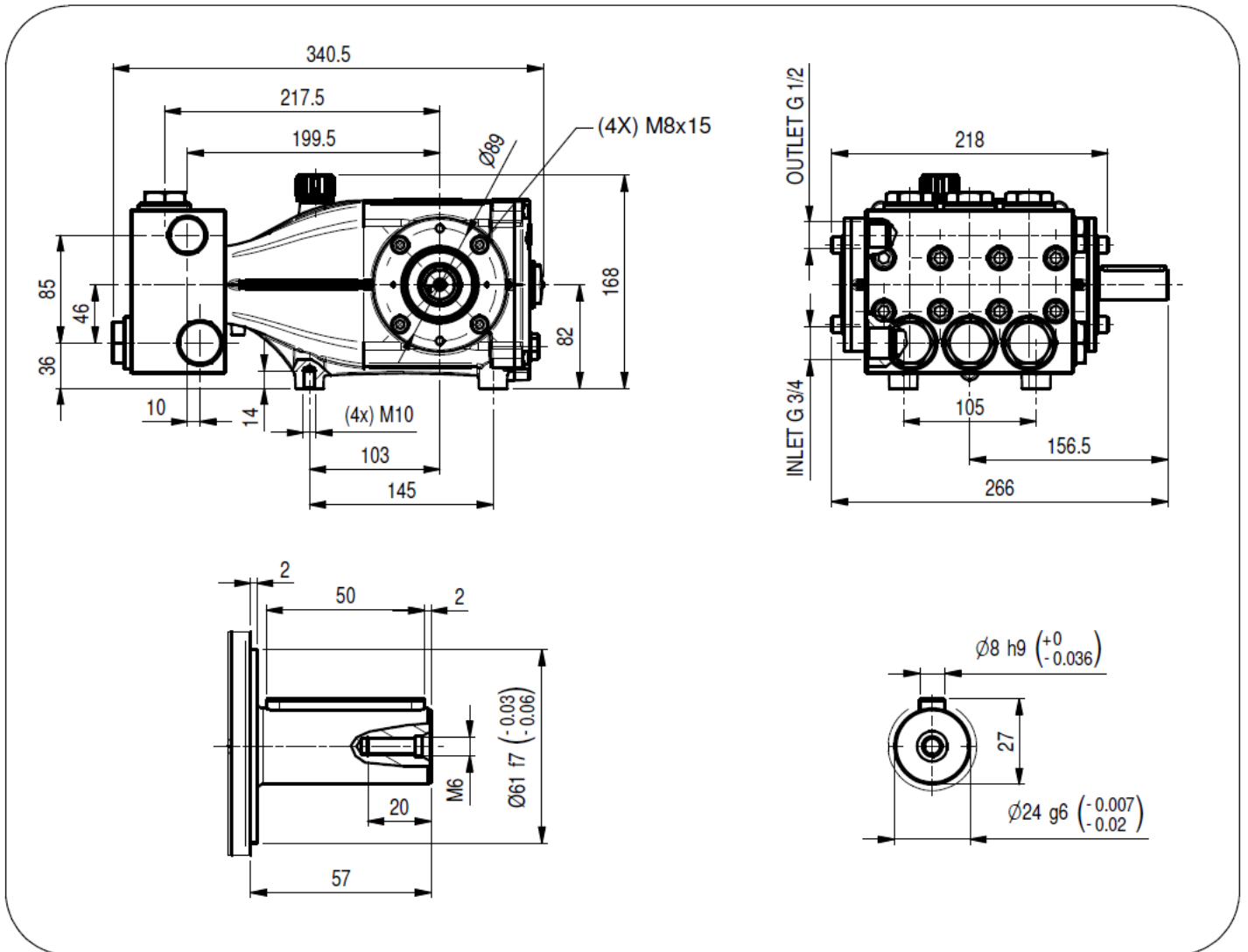

Lubrificazione: Olio SAE 10W40
Capacità: 1.2 Litri
Peso pompa: 19.5 kg

Lubrication: SAE 10W40 Oil
Capacity: 1.2 Litres
Weight: 19.5 kg

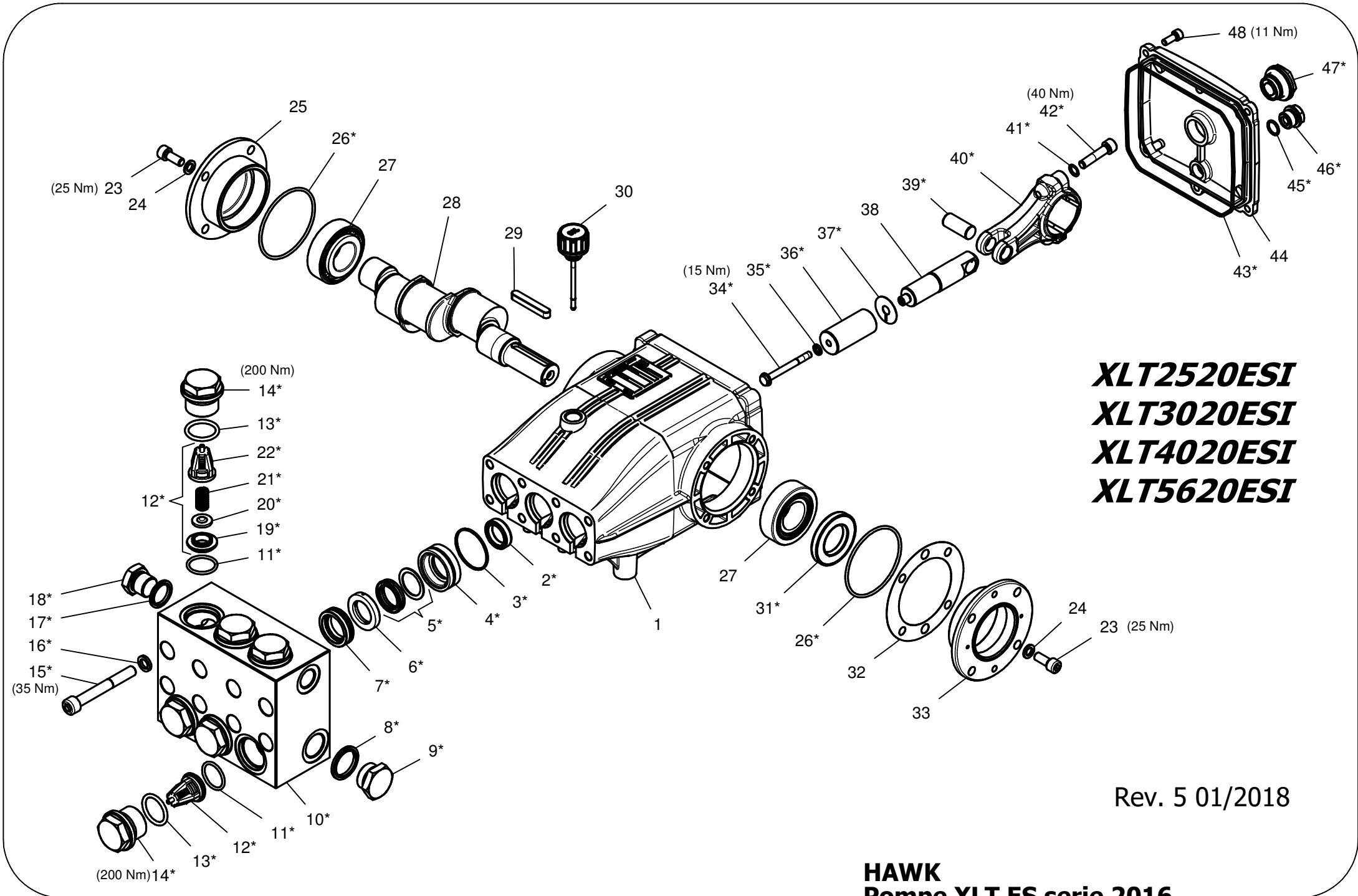

XLT2520ESI
XLT3020ESI
XLT4020ESI
XLT5620ESI

Rev. 5 01/2018

HAWK
Pompe XLT ES serie 2016
XLT ES pumps 2016 series

XLT ES 2016 SERIES

ORDINARY MAINTENANCE KIT / KIT MANUTENZIONE ORDINARIA

KIT	Item Pos.	Part Number Codice	Description	Descrizione	Q.TY by Pump Q.TA per Pompa	XLT2520ESI	XLT3020ESI	XLT4020ESI	XLT5620ESI
A	3- 5- 7	1.904-464.0	PLUNGER SEALS DIA. 25 mm	GUARNIZIONI PISTONE Ø25	1	•	•	•	•
B	11- 12 (19- 20 21- 22) 13	1.905-719.0	COMPLETE VALVE	VALVOLA COMPLETA	1				

EXTRAORDINARY MAINTENANCE KIT / KIT MANUTENZIONE STRAORDINARIA

KIT	Item Pos.	Part Number Codice	Description	Descrizione	Q.TY by Pump Q.TA per Pompa	XLT2520ESI	XLT3020ESI	XLT4020ESI	XLT5620ESI
C	3- 4- 5- 6- 7	1.905-694.0	COMPLETE SEALS PACKING DIA. 25 mm	PACCO COMPLETO GUARNIZIONI PISTONE Ø25	1				
D	34- 35- 36- 37	1.904-466.0	PLUNGER DIA. 25 mm	PISTONE Ø25	3				
E	2	1.099-766.0	PLUNGER OIL SEALS	ANELLI TENUTA OLIO ASTA	1				
F	26- 31- 43- 45 46- 47	1.905-613.0	KIT CRANKCASE SEALS	KIT TENUTE CARTER	1	•	•	•	•
H	3- 4- 5- 6- 7- 8 9- 10- 11- 12 (19- 20 21- 22) 13- 14- 15- 16 17- 18	1.904-468.0	COMPLETE MANIFOLD 25	TESTATA COMPLETA Ø25	1				
I	13- 14	1.904-329.0	VALVE PLUG ASSY	PREMONTATO TAPPO VAM	6				

“Q.TY by Pump” => Necessary quantity to repair one pump
 “Q.TA’ per Pompa” => Quantità necessaria per riparare una pompa

TOOL KIT

Part Number Codice	Description	Descrizione	Q. TY by Pump Q.TA per Pompa	XLT2520ESI	XLT3020ESI	XLT4020ESI	XLT5620ESI
1.099-665.0	TOOL-KIT	TOOL-KIT	1				
1.099-963.0	TOOL-KIT (low pressure seals)	TOOL-KIT (guarnizioni bassa pressione)	1	•	•	•	•
1.905-659.0	OIL SEAL EXTRACTOR TOOL-KIT	TOOL-KIT ESTR. PARAOLIO	1				



IMPORTANT

IMPORTANTE

***** *Part available ONLY in kit*
Disponibile SOLO in kit

(...) *Parts pre-assembled*
Parti pre-assemblate

PARTS LIST LISTA PARTI

Item Pos	Part Number Codice	Description	Descrizione	KIT	Q.TY Q.TA	XL72520ESI	XL73020ESI	XL74020ESI	XL75620ESI
1	9.850-377.0	CRANKCASE	CARTER		1				
2*		PLUNGER OIL SEAL	ANELLO RADIALE	E	3				
3*		"O" RING Ø1.78X37.82	"O" RING Ø1.78X37.82	A-C-G	3				
4*		PRESSURE RING 25MM	PRESSORE "U" Ø25	C-G	3				
5*		LOW PRESSURE "U" SEAL, DIA.25MM	ANELLO TENUTA "U" Ø25	A-C-G	3				
6*		INTERMED. RING 25MM	DIFFUSORE INTER. Ø25	C-G	3				
7*		HIGH PRESSURE "U" SEAL, DIA.25MM	ANELLO TENUTA "U" Ø25	A-C-G	3				
8*		BONDED SEAL STAINLESS STEEL G3/4	BONDED SEAL G3/4 INOX	G	1				
9*		STAINLESS STEEL PLUG G3/4	TAPPO G3/4 INOX	G	1				
10*		MANIFOLD HOUSING	TESTATA	G	1				
11*		"O" RING Ø2.62X25.07	"O" RING Ø2.62X25.07	B-G	6				
12*		VALVE ASSEMBLY	VALVOLA PREMONTATA	B-G	6				
13*		"O" RING Ø2.62X26.58	"O" RING Ø2.62X26.58	B-G-I	6				
14*		STAINLESS STEEL VALVE PLUG	TAPPO VALVOLA INOX	G-I	6	•	•	•	•
15*		MANIFOLD STUD BOLT STAINLESS STEEL	VITE TCEI M10X80 INOX A2-70	G	8				
16*		LOCK WASHER STAINLESS STEEL	ROSETTA ELASTICA Ø10,2 INOX	G	8				
17*		BONDED SEAL STAINLESS STEEL G1/2	BONDED SEAL G1/2 INOX	G	1				
18*		STAINLESS STEEL PLUG G1/2	TAPPO G1/2 INOX	G	1				
19*		VALVE SEAT	SEDE VALVOLA	B-G	6				
20*		VALVE PLATE	PIATTELLO VALVOLA	B-G	6				
21*		VALVE SPRING	MOLLA VALVOLA	B-G	6				
22*		VALVE CAGE	GABBIA VALVOLA	B-G	6				
23	9.851-476.0	SCREW M8X20 STAINLESS STEEL	VITE TCEI M8X20 INOX		8				
24	9.851-133.0	LOCK WASHER STAINLESS STEEL	ROSETTA ELASTICA Ø10,2 INOX		8				
25	9.850-620.0	CLOSED BEARING HOUSING	FLANGIA CHIUSA		1				
26*		"O" RING Ø2.62X71.12	"O" RING Ø2.62X71.12	F	2				
27	9.850-347.0	ROLLER BEARING	CUSCINETTO A RULLI		2				
28	9.850-193.0	CRANKSHAFT DIA. 24 MM	ALBERO Ø24		1				•
	9.850-194.0	" " " "	" "						•
	9.850-195.0	" " " "	" "						•
	9.850-222.0	" " " "	" "						•
29	9.850-447.0	CRANKSHAFT KET	CHIAVETTA		1				
30	9.851-287.0	OIL DIP STICK	TAPPO LIVELLO OLIO		1				
31	9.850-000.0	CRANKSHAFT SEAL	ANELLO RADIALE		1				
32	9.850-546.0	SHIM	DISTANZIALE		1				
33	9.850-610.0	BEARING HOUSING	FLANGIA APERTA		1	•	•	•	•
34*		PLUNGER BOLT	VITE PISTONE	D	3				
35*		BONDED SEAL	BONDED SEAL	D	3				
36*		PLUNGER DIA. 25 MM	PISTONE Ø25	D	3				

Item Pos	Part Number Codice	Description	Descrizione	KIT	Q.TY Q.T À	XL T2520ESI	XL T3020ESI	XL T4020ESI	XL T5620ESI
37*		STAINLESS STEEL SPACER	ROSETTA INOX	D	3				
38*		PLUNGER ROD	ASTA PISTONE	H	3				
39*		CONNECTING ROD PIN	SPINOTTO	H	3				
40*		CONNECTING ROD	BIELLA	H	3				
41*		SPRING WASHER	ROSETTA ELASTICA Ø8	H	6				
42*		CONNECTING ROD SCREW	VITE BIELLA	H	6				
43*		"O" RING Ø2.62X152.07	"O" RING Ø2.62X152.07	F	1	•	•	•	•
44	9.850-389.0	CRANKCASE COVER	COPERCHIO		1				
45*		"O" RING Ø1.78X14.00	"O" RING Ø1.78X14.00	F	1				
46*		BRASS PLUG G 3/8	TAPPO OTTONE G 3/8	F	1				
47*		SIGHT GLASS, G 3/4	SPIA LIVELLO OLIO	F	1				
48	9.851-475.0	COVER SCREW STAINLESS STEEL	VITE M6X16 INOX		5				