

	EQUIPAGGIAMENTI TECNICI LAVAGGIO	26.1070.00 26.1076.00 26.1080.00 GIUNTO GIREVOLE SW5 SWIVEL SW5	①	5
			Ⓜ	

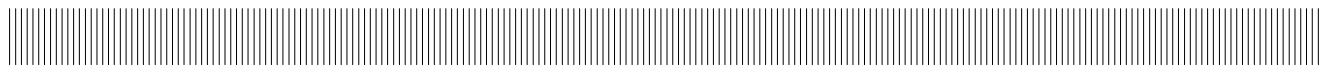

SPECIFICHE TECNICHE SPECIFICATIONS

- PRESSIONE NOMINALE <i>RATED PRESSURE</i>	200 bar – 20 MPa (2900 psi)		
- PRESSIONE CONSENTITA <i>PERMISSIBLE PRESSURE</i>	220 bar – 22 MPa (3200 psi)		
- PORTATA MASSIMA <i>MAX FLOW RATE</i>	160 l/min (42 USG p.m.)		
- TEMPERATURA MASSIMA DI LAVORO (UTILIZZO CONTINUO) <i>MAX WORKING TEMPERATURE (CONTINUOUS USE)</i>	90° C (194 °F)		
- TEMPERATURA MASSIMA AMMESSA (SOLO PER BREVI PERIODI) <i>MAX PERMISSIBLE TEMPERATURE (FOR SHORT PERIODS ONLY)</i>	160° C (320 °F)		
- NUMERO DI GIRI MAX. <i>MAX RPM</i>	30		
- COPPIA ALLA PRESSIONE NOMINALE <i>TORQUE AT RATED PRESSURE</i>	26.1070.00	29.1076.00	~1.9 Nm (16.8 Lbs.in)
		26.1080.00	~1.5 Nm (13.3 Lbs.in)
- MATERIALE <i>MATERIAL</i>	26.1070.00 ACCIAIO	INOX AISI303	- 26.1076.00 INOX AISI316
		26.1080.00	OTTONE (BRASS)
- GUARNIZIONI <i>SEALS</i>	OR IN FKM (VITON) O-RING SEALS IN FKM (VITON)		

MISURE D'INGOMBRO OVERALL DIMENSIONS

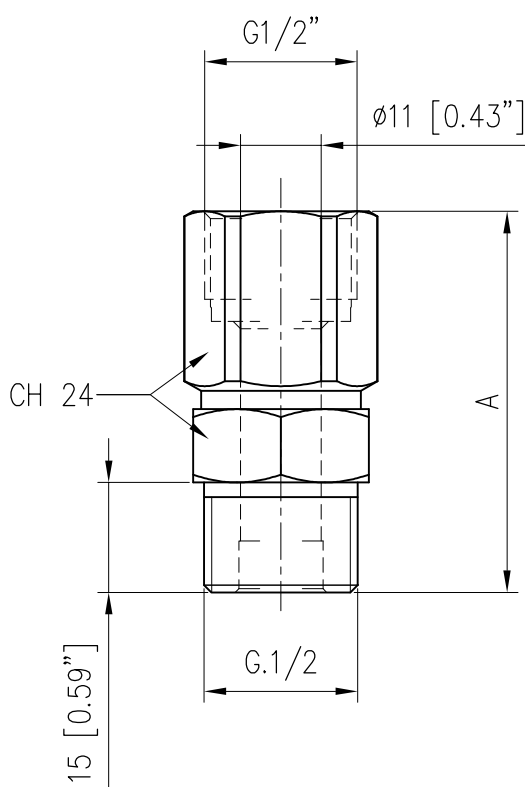

CODICE <i>CODE</i>	MATERIALE <i>MATERIAL</i>	A
26.1070.00	INOX AISI303 S.S.T.	52
26.1076.00	INOX AISI316 S.S.T.	52
26.1080.00	OTTONE BRASS	55