



INTERPUMP GROUP

I
GB
F

ISTRUZIONI D'USO
INSTRUCTIONS FOR USE
MODE D'EMPLOI

D
E
P

BEDIENUNGSANLEITUNG
INSTRUCCIONES DE USO
INSTRUÇÕES DE USO

Questo manuale deve essere letto e compreso in accordo al libretto generico "Istruzioni d'uso e manutenzione".
This manual must be read and followed in accordance with the generic "Instructions for Use and Maintenance" booklet.
Ce manuel doit être lu et compris en accord avec la notice générale "Mode d'emploi et d'entretien".
Dieses Handbuch ist in Verbindung mit dem allgemeinen Handbuch "Gebrauchs- und Wartungsanleitung" zu lesen und zu verstehen.
Este manual debe leerse y comprenderse de acuerdo con el manual general "Instrucciones de uso y mantenimiento".
Este manual deve ser lido e interpretado de acordo com o livro genérico "Instruções de uso e manutenção".

50



S
E
R
I
E
S

Type Type Type Tipo Tipo	Flow rate Débit Förderstrom Caudal Portata		Pressure Pressione Druck Presion Pressione			rpm t/m upm r/m g/m	Power Puissance Leistung Potencia Potenza		Weight Poids Gewicht Peso Massa		
	L/min	gpm	bar	MPa	psi		Hp	kW	Kg	Ibs	
W70	11	2.90	70	7	1015	1450	2.0	1.47	6.5	14.33	0.43
W71	13	3.43	70	7	1015	1450	2.5	1.83	6.5	14.33	0.43
W91	13	3.43	90	9	1300	1450	3.0	2.20	6.5	14.33	0.43
W98	11	2.90	100	10	1450	1450	3.0	2.20	8.5	18.73	0.43
W99	13	3.43	100	10	1450	1450	3.3	2.42	8.5	18.73	0.43
WS137	13	3.43	120	12	1750	1450	4.0	2.94	8.7	19.18	0.43
WS149	11	2.90	140	14	2030	1450	4.0	2.94	8.7	19.18	0.43
W996	15	3.96	75	7.5	1100	1750	3.0	2.20	8.5	18.73	0.43
W995	13	3.43	90	9	1300	1750	3.0	2.20	8.5	18.73	0.43
W997	15	3.96	140	14	2030	1750	5.5	4.04	8.7	19.18	0.43
WW141	11.5	3.04	140	14	2030	2800	4.0	2.94	8.5	18.73	0.43
WW161	14	3.69	160	16	2320	2800	5.5	4.04	8.5	18.73	0.43
WW935	13.2	3.48	172	17.2	2500	3400	6.0	4.41	8.5	18.73	0.43
WW944	16.6	4.38	172	17.2	2500	3400	7.5	5.51	8.5	18.73	0.43



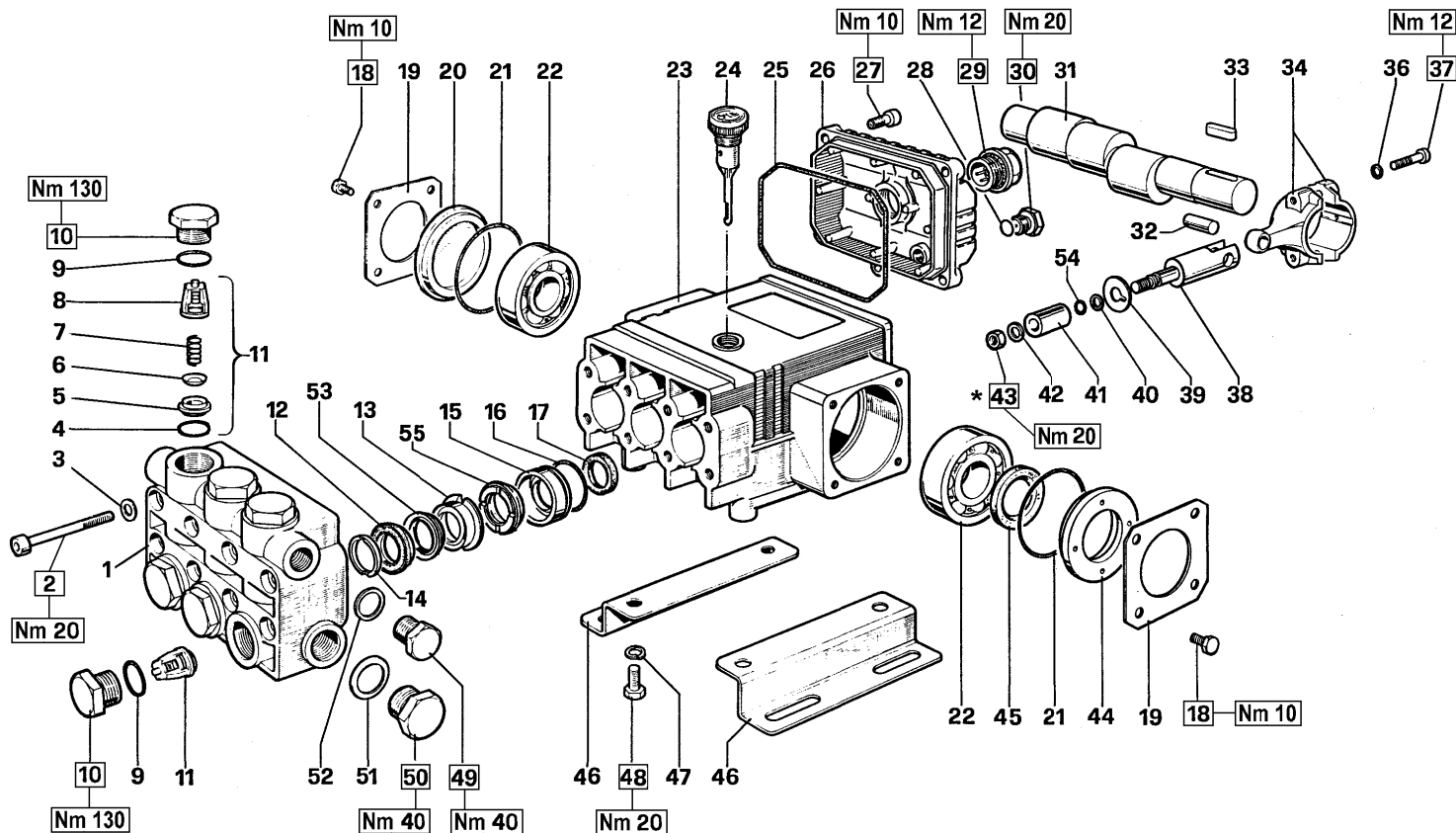

- * Fissare con Loctite 542 col. ROSSO
- * Affix with Loctite 542 col. RED
- * Fixer avec de la Loctite 542 couleur ROUGE
- * Mit Loctite 542 ROT befestigen
- * Fijar con Loctite 542 col. ROJO
- * Fixar com Loctite 542 cor. VERMELHA

**KIT RICAMBI – SPARE KITS****WW141 – WW161
WW935 - WW944**

KIT Nr.	KIT 1	KIT 4	KIT 23	KIT 88	KIT 89	KIT 90	KIT 91	KIT 92
Posizioni include Positions included	4 – 5 6 – 7 8 (11)	9 - 10	17	12 – 53 55	13	14	15 - 16	12 – 13 14 – 15 16 – 53 55
Nr. Pcs.	6	6	3	3	3	6	3	1

POS	COD.	DESCRIZIONE – DESCRIPTION - KIT	NR
1	50.1205.41	Testata pompa Ø 15	1
2	99.3175.00	Vite M8x60 UNI 5931	8
3	96.7014.00	Rosetta Ø 8.4x13x0.8	8
4	90.3841.00	OR Ø 17.13x2.62 (3068)	1 6
5	36.2003.66	Sede valvola	1 6
6	36.2001.76	Valvola sferica	1 6
7	94.7376.00	Molla Ø 9.4x14.8	1 6
8	36.2002.51	Guida valvola	1 6
9	90.3847.00	OR Ø 20.24x2.62 90 Sh. (3081)	4 6
10	98.2220.00	Tappo M24x2x16.5	4 6
11	36.7032.01	Gruppo valvola aspiraz./mandata	1 6
12	90.2620.00	Anello ten. alt. Ø15x25x5/3.1 HP 88-92	3
13	52.2166.70	Anello intermedio Ø 15	89-92 3
14	51.1000.51	Anello di testa Ø 15	90-92 3
15	52.0805.70	Anello di fondo Ø 15	91-92 3
16	90.3612.00	OR Ø 31.47x1.78 (2125)	91-92 3
17	90.1614.00	Anello rad. Ø 20x30x5	23 3
18	99.1807.00	Vite M6x10 UNI 5739	8
19	50.1500.74	Coperchio laterale carter	2
20	50.2116.51	Distanziale	1
21	90.4097.00	OR Ø 55.56x3.53 (159)	2
22	91.8329.00	Cuscinetto a sfere 6305	2

POS	COD.	DESCRIZIONE – DESCRIPTION - KIT	NR
23	50.0104.22	Carter pompa	1
24	98.2103.00	Tappo carico olio G 3/8"	1
25	90.3920.00	OR Ø 101.27x2.62 (3400)	1
26	50.1600.22	Coperchio posteriore carter	1
27	99.1837.00	Vite M6x14 UNI 5931	5
28	90.3585.00	OR Ø 10.82x1.78 (2043)	4
29	97.5968.00	Spia livello olio G 3/4"	1
30	98.2042.50	Tappo G 1/4"x9 TE17 – Zinc.	1
31	50.0201.35 50.0205.35	Albero – ww161-ww944 Albero – ww141-ww935	1 1
32	97.7330.00	Spinotto Ø 9x19.5	3
33	91.4878.00	Linguetta 8x7x25 UNI 6604	1
34	50.0300.01	Biella completa	3
36	96.6939.00	Rosetta Ø6.4x10x0.7	6
37	99.1927.00	Vite M6x35 UNI 5931	6
38	52.0500.56	Guida pistone	3
39	96.7070.00	Rosetta Ø 9x23x0.5	3
40	90.5022.00	Anello antiest. Ø 6.2x9x1.5	3
41	52.0400.09	Pistone Ø 15x37.5	3
42	96.7008.70	Rosetta Ø 8x13x1	3
43	92.2216.00	Dado M8x13x5 - INOX	3
44	50.2115.51	Distanziale	1

POS	COD.	DESCRIZIONE – DESCRIPTION - KIT	NR
45	90.1634.00	Anello rad. Ø 25x42x7	1
46	50.2000.74	Piedino pompa	2
47	96.7016.00	Rosetta Ø 8.4 UNI 1751	4
48	99.3037.00	Vite M8x16 UNI 5739	4
49	98.2100.00	Tappo G 3/8"x13	1
50	98.2176.00	Tappo G 1/2"x10	1
51	96.7514.00	Rosetta Ø 21.5x27x1.5	1
52	96.7380.00	Rosetta Ø 17.5x23x1.5	1
53	90.2622.00	Anello RESTOP Ø 15x25x5/3.1 88-92	3
54	90.3572.00	OR Ø 5.28x1.78 (2021)	3
55	90.2617.00	Anello ten. alt. Ø 15x25x5.8 LP 88-92	3

1 - CAMBIO OLIO

- 1.1 – Il cambio dell'olio va eseguito con pompa a temperatura di lavoro.
- 1.2 – Posizionare un recipiente sotto il tappo di scarico olio (3).
- 1.3 – Rimuovere il tappo con asta (1) e successivamente il tappo di scarico (3).
- 1.4 – Attendere fino a quando tutto l'olio è uscito, quindi riavvitare il tappo di scarico (3) con la coppia torcente indicata su disegno esploso.
- 1.5 – Riempire con olio nuovo fino al raggiungimento della mezzeria del tappo spia livello olio (2) e riavvitare il tappo con asta (1).

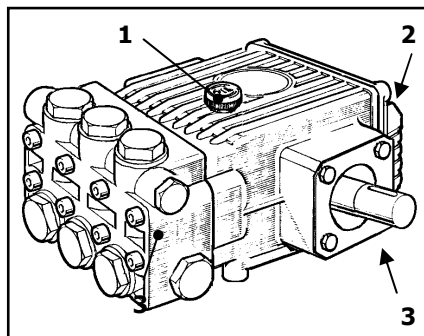

Per il tipo di olio da utilizzare fare riferimento a quanto indicato sul libretto generico.



ATTENZIONE: L'olio esausto deve essere raccolto in recipienti e smaltito negli appositi centri in accordo alla normativa vigente. Non deve essere assolutamente disperso nell'ambiente.

1 – OIL CHANGING

- 1.1 – Oil changing must be done with the pump at operating temperature.
- 1.2 – Put a container under the oil drain plug (3).
- 1.3 – Remove the oil dipstick (1) and then the drain plug (3).
- 1.4 – Wait until all the oil has drained out, then screw the drain plug (3) and tighten at the torque shown in the exploded diagram.
- 1.5 – Fill with new oil until the middle of the oil level indicator (2) is reached, screw by hand the oil dipstick (1).

Refer to the generic booklet for the type of oil to use.



WARNING: The exhaust oil must be collected in receptacles and disposed of at authorised centres as specified by law. It must not be thrown away in the environment.

1 - CHANGEMENT DE L'HUILE

- 1.1 – Le changement de l'huile doit être exécuté avec la pompe à température d'exercice.
- 1.2 – Placer un récipient sous le bouchon de vidange de l'huile (3).
- 1.3 – Enlever le bouchon-jauge (1), puis enlever le bouchon de vidange (3).
- 1.4 – Attendre que toute l'huile soit sortie, puis revisser le bouchon de vidange (3) avec le couple de torsion qui est indiqué sur le dessin éclaté.
- 1.5 – Remplir avec de l'huile neuve jusqu'à la ligne médiane du bouchon indicateur du niveau d'huile (2), et revisser le bouchon-jauge (1).

Pour le type d'huile à utiliser, se référer à ce qui est indiqué sur la notice générale.



ATTENTION : L'huile usée doit être recueillie dans des récipients et éliminée dans les centres prévus à cet effet, conformément à la réglementation en vigueur. Il ne faut absolument pas la jeter dans l'environnement.